



2011 EASTERN CANADIAN KARTING CHAMPIONSHIP Supplementary Regulations

RACE 3 - May 29 2011
Karting Trois-Rivieres, Trois-Rivières, Québec

Categories of Competition:

- Rotax DD2 (Masters)
- Rotax Max Senior (Masters)
- Rotax DD2
- Rotax Max Senior
- Rotax Max Junior
- Rotax Mini-Max
- Rotax Micro-Max
- 4 Strokes Senior (Honda and Briggs)



On-Line Registration for Round 3 hosted by Karting Trois-Rivieres is available at
<http://www.eckc.ca/registration>



Contents

1. The Event.....	3
2. Sanctioning.....	3
3. Event Organizer and Event Inquires.....	3
4. The Track.....	3
5. Sportsmanship Theme.....	3
6. Registration Fees.....	4
7. Eligible Entries and Licence Requirements.....	4
8. Tires to be Used.....	4
9. Tents and Pit Space.....	5
10. Event Officials.....	5
11. Regulations and Precedence of Regulations.....	5
12. Changes to Regulations.....	6
13. Eastern Canadian Karting Championship Class Structure.....	6
14. Competition Numbers for Rotax Classes.....	6
15. Rotax Micro MAX and Rotax Mini MAX.....	7
16. Tire and Oil Specifications.....	8
17. Practice Days Fee.....	9
18. Paddock Spaces.....	9
19. Participant Registration at the Event.....	9
20. Registration Process.....	9
21. Restricted Areas.....	9
22. Driver Briefings.....	9
23. Number of Karts on the Race Track.....	10
24. Qualifying Procedures.....	10
25. Transponders.....	10
26. Transponder Mounting Location.....	10
27. Marking of Engine and Tires.....	11
28. Re-starting Karts.....	11
29. Race Starts.....	12
30. Use of The Blue With Red “X” Overlap Flag.....	13
31. Procedure at the End of a Qualifying Session or Race.....	14
32. Procedure at the End of Finals.....	14
33. Official Notice Board.....	14
34. Fuel.....	14
35. Hotel accomodation.....	14
36. Quiet Rule.....	14

1. The Event

The event is organized by the hosting facility.

2. Sanctioning

The event is sanctioned by ASN Canada FIA.

3. Event Organizer and Event Inquires

CKEQ

4140 St-Charles
Trois-Rivieres, Quebec, Canada, G9B 7W9
Tel: (819) 377-5566
Fax: (819) 377-3249
E-mail: info@ckeq.com

4. The Track

The track is run in a counter-clockwise direction.

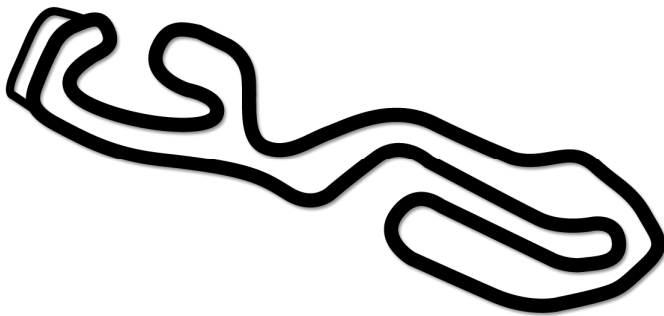

5. Sportsmanship Theme

Participants in the Eastern Canada Rotax Challenge shall conduct themselves according to the highest standards of behaviour and sportsmanship, particularly in relations with other competitors, officials, sponsors and their products, and in manner that shall not be prejudicial to the reputation of the ECKC ASN, promoters, sponsors, organisers, or to karting sport in general. Sportsmanship means any person's conduct and behaviour while participating in a sport. Examples are fairness, respect for one's opponent, and graciousness in winning or losing. Failure to do so may result in penalties.

Entrants or drivers are at all times responsible for the conduct of their crewmembers and guests. A violation of these Regulations committed by an entrant, driver, crewmember or guest may be directly chargeable to the entrant or driver and result in penalties that may ultimately affect the outcome of the competition.

6. Registration Fees

Each commitment is entitled of a pass for a mechanic. Accreditation will be to the track on **Friday from 11:00 am to 1:00 pm and from 3:00 pm to 6:00 pm for accreditation and the purchase of tires and Saturday from 7:30 am to 8:30 am for the accreditation and tire purchase.** All persons listed on the site (officials, organizers, drivers, crew, volunteers) must sign the waiver form.

Rotax Class Registration Rotax DD2 (Masters), Rotax Senior (Master), Rotax Junior Includes 1 Driver Pass, 1 Mechanic Pass, paddock space 20'X20'	\$135.00 per race
Rotax Mini-Max, Rotax Micro-Max Includes 1 Driver Pass, 1 Mechanic Pass, paddock space 20'X20'	\$115.00 per race
Support Class Registration 4 Strokes Senior (Honda and Briggs) Includes 1 Driver Pass, 1 Mechanic Pass, paddock space 20'X20'	\$100.00 per race
Transponder Rental (Drivers may provide their own transponders)	\$15.00 per race
Pre-Event Controlled Practice (May 27th: 9:00 am to 17:00 pm)	\$60.00 per driver

Kart numbers will not be reserved until registration payment is complete.

7. Eligible Entries and Licence Requirements

- a) Residents of Canada – Canadian residents must be members in good standing of any ASN Canada FIA affiliated kart club. They may enter any ECKC Class provided they possess the appropriate license, their kart meets the appropriate technical requirements, and the driver meets the entry qualifications for their particular class.

NOTE: Only permanent residents of Canada are eligible to qualify for the Rotax classes at the 2011 ASN Canada FIA Canadian Karting Championships

- b) Registration – At the event, registration fees must be paid by cash or credit card. **A 20\$ administration fees will apply, when registering on site.**
- c) If your pre-registration cheque is not honoured by your bank, a \$50.00 fee will apply
- d) Participant Info. – All participants and crew members must read and sign a waiver form. No participant will be allowed to practice on Friday until they have registered for the event.
- e) Upon completion of all paperwork and the payment of all fees, participants will be issued documentation and passes. Lost passes for drivers and mechanics may be replaced for a fee of \$10.00.

8. Tires to be Used

- **Mojo D2 must be CIK front and rear.**
 - **Mojo D3 must be Non CIK front and rear.**
- a) Tires – All participants are required to purchase race tires for the 2011 Eastern Canadian Karting Championship at the event. All tires will be branded with the exception of rain tires. Participants

can provide their own rain tires and/or practice tires. Tires will be available for pick up the morning of each race. Tire vouchers will be sold at registration for each of the six events.

- b) Please note that in Rotax Junior, Rotax Senior (Masters), and Rotax DD2 (Masters) a minimum of one set must be purchased for each of four rounds. Competitors in these classes have the OPTION to run new tires in each of the six races if they so choose.
- c) In Rotax Micro-Max, Rotax Mini-Max, a maximum of one set can be used in each of the four rounds.
- d) In 4 Strokes Senior, drivers must purchase race tires from an ECKC event. Drivers have the option to use new tires for each of the four rounds or may choose to re-use the same tires in the next rounds.

9. Tents and Pit Space

Contact Louis-Philippe Gelin as by phone at 514-804-4775. Pit spots will be assigned on a first come, first serve basis. Official teams, large teams, and series sponsors will have priority.

10. Event Officials

Registrar:	CKEQ
Race Director:	Bill Oakman
Technical Inspector:	Pierre Laberge
Race Starter:	ASRQ
Timing and Scoring:	Vincent Mathieu
Race Steward:	Norman Jennings Denys Beaudin

11. Regulations and Precedence of Regulations

The event will be run in accordance with the 2011 ASN Canada FIA Canadian Karting Regulations Book 1 Sporting Regulations and Book 2 Technical Regulations, Canadian Karting 4 Strokes Regulations (available at www.asncanada.com), Rotax Max Challenge Regulations (RMC - available at www.maxchallenge.ca).

The Regulations shall be as follows (in order of precedence):

- a) 2011 ASN Canada FIA Canadian Karting Regulations.
- b) ASN Bulletins.
- c) ASN issued Rotax Max Challenge Regulations.
- d) These Supplementary Regulations.
- e) Official Bulletins issued before and at the event.
- f) Instructions from approved Officials.

Any claim of lack of knowledge of the Regulations will not be entertained.

12. Changes to Regulations

These supplementary regulations can only be amended or changed by the Eastern Canadian Karting Championship Organizers and by the Race Steward as necessary.

The Schedule of track sessions and races may be adjusted by the event organizers and officials.

13. Eastern Canadian Karting Championship Class Structure

Class	Grade	Age	Engine Rules	Weight Kg.	Weight Lbs.
Rotax DD2	B	15 th birthday during the current calendar year	RMC	173	381
Rotax DD2 Master	C	32 nd birthday during the current calendar year	RMC	180	397
Rotax Max Senior	B	15 th birthday during the current calendar year	RMC	165	364
Rotax Max Senior Master	C	32 nd birthday during the current calendar year	RMC	173	405
Rotax Max Junior	C	13 th birthday during the current calendar year, 17 th birthday after December 31 st of the current calendar year	RMC	145	320
Rotax Mini-Max	C	10 to 13 years old	RMC	131.5	290
Rotax Micro-Max	C	8 to 10 years old	RMC	106.5	235
Honda Senior	C	15 th birthday during the current calendar year	ASN	149.7	330

14. Competition Numbers for Rotax Classes

All Rotax karts must have a unique number of three digits made up of numerals only except Rotax Micro MAX. The first digit in each three-digit number must correspond to the table below. No letters will be allowed.

Rotax Micro MAX	00	ROTAX Junior MAX	200	Rotax DD2	400
Rotax Mini MAX	100	Rotax MAX	300	Rotax DD2 Masters	500

15. Rotax Micro MAX and Rotax Mini MAX

Gear Ratio and Carburetor Set-ups - The following specifications are mandatory for all Trois-Rivieres.

Rotax Micro MAX

Gear Ratio:

Front sprocket: 14 - Rear sprocket: 73

Carburation:

Needle: K98

Combination 2: Floats are marked with "gr 3.6"

Idle/Pilot jets inner and outer, are both stamped with the digits "60".

Starter Jet is stamped with the digit "60".

8.5 venturi

Main Jet: 125

Rotax Mini MAX

Gear Ratio:

Front sprocket: 13 - Rear sprocket: 82

Carburation:

Needle: K98

Combination 1:

Floats are marked with "gr 5.2"

Idle/Pilot jets inner and outer, are both stamped with the digit "30".

Starter jet is stamped with the digit "60".

Venturi 12.5

Main Jet: 152

16. Tire and Oil Specifications

- Mojo D2 must be CIK front and rear.
- Mojo D3 must be Non CIK front and rear.

Class	Type	Tire	Model	Front Size	Rear Size	Oil
Rotax DD2	Dry	MOJO	D3	10x4.50-5	11x7.10-5	XPS
	Rain	MOJO	W2	10x4.20-5	11x6.00-5	Karttec
Rotax DD2 Master	Dry	MOJO	D3	10x4.50-5	11x7.10-5	XPS
	Rain	MOJO	W2	10x4.20-5	11x6.00-5	Karttec
Rotax Max Senior	Dry	MOJO	D2	10x4.50-5	11x7.10-5	XPS
	Rain	MOJO	W2	10x4.20-5	11x6.00-5	Karttec
Rotax Max Junior	Dry	MOJO	D2	10x4.50-5.00	11x7.10-5	XPS
	Rain	MOJO	W2	10x4.20-5	11x6.00-5	Karttec
Rotax Max Senior Master	Dry	VEGA	NORD-AM	10x4.60-5	11x6.50-5	XPS
	Rain	VEGA	W5	10x4.20-5	11x6.00-5	Karttec
Rotax Mini-Max	Dry	VEGA	NORD-AM	10x4.60-5	11x6.50-5	XPS
	Rain	VEGA	W5	10x4.20-5	11x6.00-5	Karttec
Rotax Micro-Max	Dry	VEGA	NORD-AM	10x4.60-5	10 x 4.60-5	XPS
	Rain	VEGA	W5	10x4.20-5	10x4.20-5	Karttec
4 Strokes Senior	Dry	VEGA	NORD-AM	10x4.60-5	11x6.50-5	OPEN
	Rain	VEGA	W5	10x4.20-5	11x6.00-5	

WET TIRES: Participants acquire specified wet tires from their own sources.

The quantity of WET tires may be adjusted in a future event bulletin depending on weather and track conditions.

Rotax Max Classes:

RMC regulations apply.

DRY: One set of four DRY tires for EACH race .

WET: One set of four WET tires for the entire ROUND.

4 Strokes Canada Senior:

DRY: One set of four DRY tires for the ENTIRE round .

WET: One set of four WET tires for the entire ROUND.

Rotax Mini MAX and Rotax Micro MAX:

DRY: One set of four DRY tires for the ENTIRE round.

WET: One set of four WET tires for the entire ROUND.

17. Practice Days Fee

The fee for the Official practice on Friday May 26, 2011 is \$60.00.

18. Paddock Spaces

See the Entry Form or Contact Louis-Philippe G  linas.

19. Participant Registration at the Event

Every participant admitted to the racetrack site must first register at the Registration location. All participants and crew members must read and sign a waiver form.

Participants under 18 years of age, unaccompanied by parents or guardians must produce a fully completed copy of the ASN annual Parental Consent Waiver. Forms are available at www.asncanada.com.

Participants under 18 years of age, accompanied by parents or guardians must sign a Parental Consent Waiver and all registration forms.

Upon completion of all paperwork and the payment of all fees, participants will be issued documentation and passes. Lost passes for drivers may be replaced for a fee of \$50.00. Lost passes for crew members and guests may be replaced for a fee of \$10.00.

Passes must be displayed at all times. Failure to wear or display the pass may result in refusal of entry.

20. Registration Process

At Registration, each participant must submit a fully completed Pre-Technical Inspection Self-Declaration form. Registration will issue the appropriate kart sticker only after the payment of event fees and completion of all required paperwork.

Drivers found on the track without having completed the approved Pre-Technical Inspection Self-Declaration form are subject to penalty.

All karts must bear the appropriate kart sticker before entering the track.

It is the competitor's responsibility to ensure that their kart meets the technical requirements for their class throughout the entire race event.

Any kart or driver's racing equipment is subject to Technical Inspection at any time.

21. Restricted Areas

The racetrack infield, the perimeter of the track, the Pit Lane, Pre-Grid, Grid, Scale Area and Technical Inspection areas are restricted areas.

Access to the Grid and Pit Lane is available only to participants when their class is running. One crewmember with a Mechanic's Pass is allowed on the Grid with each entry.

A Hot Pit will not be used during practice, qualification sessions or races.

Holders of Passes including team members and guests are entitled free access to the paddock and spectator areas only.

22. Driver Briefings

Drivers must attend the driver briefing on any day when they will be on the racetrack.

23. Number of Karts on the Race Track

ASN Canadian Karting Regulations Book 1, Regulation 10.3.

A maximum of 34 karts will be allowed to start in a Final. The Event Organizer and officials may alter this number.

24. Qualifying Procedures

ASN Canadian Karting Regulations Book 1, Regulation 11.3. Qualifying for a Race.

For qualifying sessions, drivers will enter the track from pre-grid only on a first-come, first-served basis. A driver can join their designated qualifying session at any time prior to the checkered flag. Drivers must exit the track only through the designated weighing area. A driver may not leave the track and enter the pits, paddock or grid and return during a qualifying session.

If a driver stops for any reason during a qualifying session the driver will be allowed one attempt to try and start again with or without assistance from race officials. A driver may not receive assistance from anyone other than an official of the event.

25. Transponders

Each kart must be equipped with a transponder mounting bracket. Brackets can be purchased at registration for a non-refundable fee of \$15.00.

Transponders are available for a rental fee of \$15.00. Drivers who wish to rent a transponder must indicate this on their entry form. Loss or damage to a transponder provided by the event organizers will incur a cost of \$300.00 to the driver.

Drivers who have their own AMB-compatible transponders must register them on the entry form or at the time of event registration.

26. Transponder Mounting Location

The competitor is responsible for securing the scoring transponder to the kart to prevent loss of the transponder. The transponder must be mounted on the center of the rear of the driver seat. Minor offset from the center of the seat is permitted.

The transponder must be mounted vertically (inscription readable normally) with the center of the transponder installed 25 cm +/- 5 cm from ground level.

The space, in a right line, between the transponder and the ground must be free, i.e. no lead, chassis tubing, battery or other element which can block the signal between the transponder and the detecting loop.

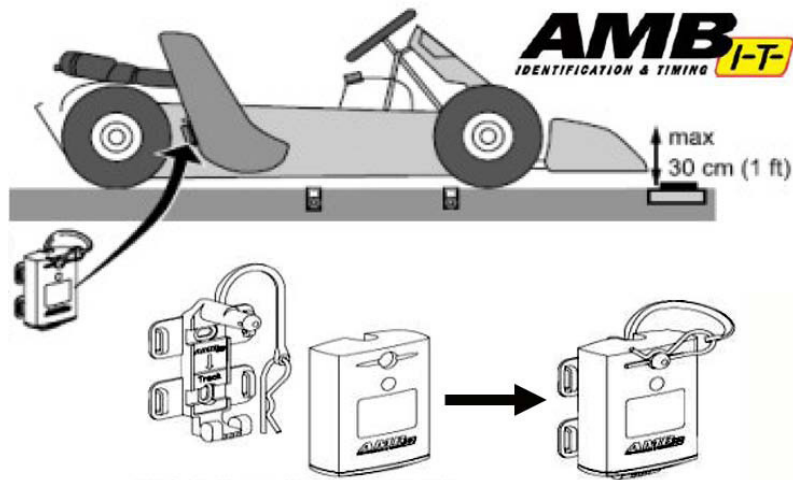

27. Marking of Engine and Tires

Engines and tires will be marked either before or after qualification sessions. It is the driver's responsibility to be sure that their engine and tires are marked before leaving the Scale Area.

28. Re-starting Karts

ASN Canadian Karting Regulations Book 1, Regulations 11.14. Re-starting Karts.

Should a kart stop on the racetrack whether the engine is running or not, and there is no perceived imminent danger, the driver may attempt to restart the kart without assistance other than from officials.

The officials may provide assistance but are not obliged to do so.

Should a kart stop on the racetrack, whether the engine is running or not, the officials may order the kart to be removed immediately for safety reasons. Once ordered removed, a kart may not rejoin the track session.

In the opinion of the officials, should attempts to restart appear to be unsuccessful or are taking too much time, or possibly endangering the driver or others, the kart is to be removed from the track when the driver is instructed to do so by the officials.

For Qualifying and Race sessions:

If during a qualifying session or race a kart is taken to the pit or paddock area, it is not permitted to rejoin the track unless the supplementary regulations for the event state otherwise.

Failure to follow the regulations above and/or instructions from the officials may result in penalties including loss of times, exclusion and additional penalties.

The regulations above are not subject to protest or appeal.

29. Race Starts

a) The Starting Grid:

A Yellow Line shall be painted 25 m prior to the Start Line. This Yellow Line will also be indicated by soft cones (1 cone on each side of the track). This is the Acceleration Line.

Approaching the starting area, there will be two 2-metre wide starting lanes.

From the yellow line to the start line, the two starting lanes will be separated by three soft cones placed by the officials during the second formation lap. The cones will be removed after the start.

b) The Start Procedure:

There will be a marked Formation Line on the racetrack. Typically the Formation Line shall be located no less than 2 corners prior to the starting area. The Formation Line shall be additionally marked by two soft cones at the edge of the track.

There will be two laps prior to the start of a race. On the first lap, drivers maintain their starting grid order.

Drivers that become out of position on the track are allowed to regain their position only prior to reaching the Formation Line on the second lap.

From the start of the second lap, the Starter and all marshal stations will display a yellow flag. No passing is allowed unless a driver is regaining position prior to reaching the Formation Line on the second lap.

Karts must slow down after crossing the Finish Line at the completion of the first formation lap. The two front drivers are responsible for reducing the pace of the field during the second formation lap. Karts should be formed in rows of two and traveling at a slow constant pace prior to reaching the Formation Line during the second formation lap. Failure to do so may result in penalties to one or both of the two front drivers.

From the Formation Line to the start area, the two front drivers are responsible to maintain a reduced and constant speed and to maintain grid formation. Drivers may not accelerate until passing the yellow Acceleration Line.

Drivers must maintain position in their own lane for the start and are not allowed to pass until they have crossed the Start Line.

A Driver who fails to maintain the speed of the pack during the approach to the Start Line is liable to be sanctioned by the Stewards, to a maximum penalty of 10 seconds.

A driver exceeding the limits of their marked lane prior to the Start Line is liable to a time penalty by the Stewards. A driver will receive a 3 second penalty for partly crossing the lanes and a 10 second penalty for completely leaving their lane.

c) The Start Signal:

If the formation is satisfactory, the Start Signal will be given by switching off the Red Lights or the display of a Green Flag.

If the Starter is not satisfied with the procedure, a Yellow Light or Yellow Flag will be displayed by the Starter and all marshal stations will display a Yellow Flag.

d) Restart:

If the formation is not satisfactory, one more lap will be completed. Drivers will reform by the Formation Line and again the two front drivers are responsible to maintain a reduced and constant speed and maintain grid formation.

e) Race Stoppage Due to Unsatisfactory Start:

Should the Starter be unable to start a race because of the behaviour of the drivers, the Race Director may display a Red Flag. Drivers must slow down immediately and proceed to the Start Line, come to a complete stop in grid position, and await instructions from the Officials.

f) Starting Penalties:

One false or jump start may be allowed. Any additional false or jump start will subject the violators to a maximum penalty of 20 seconds.

A jump start exists when a kart is more than about ½ its length ahead of the kart on the same starting row. (The kart that is ahead may not have jumped the start).

Starting violation time penalties are added to the competitors finishing time.

Start procedure penalties are not subject to protest or appeal.

g) Starting Grid Marking

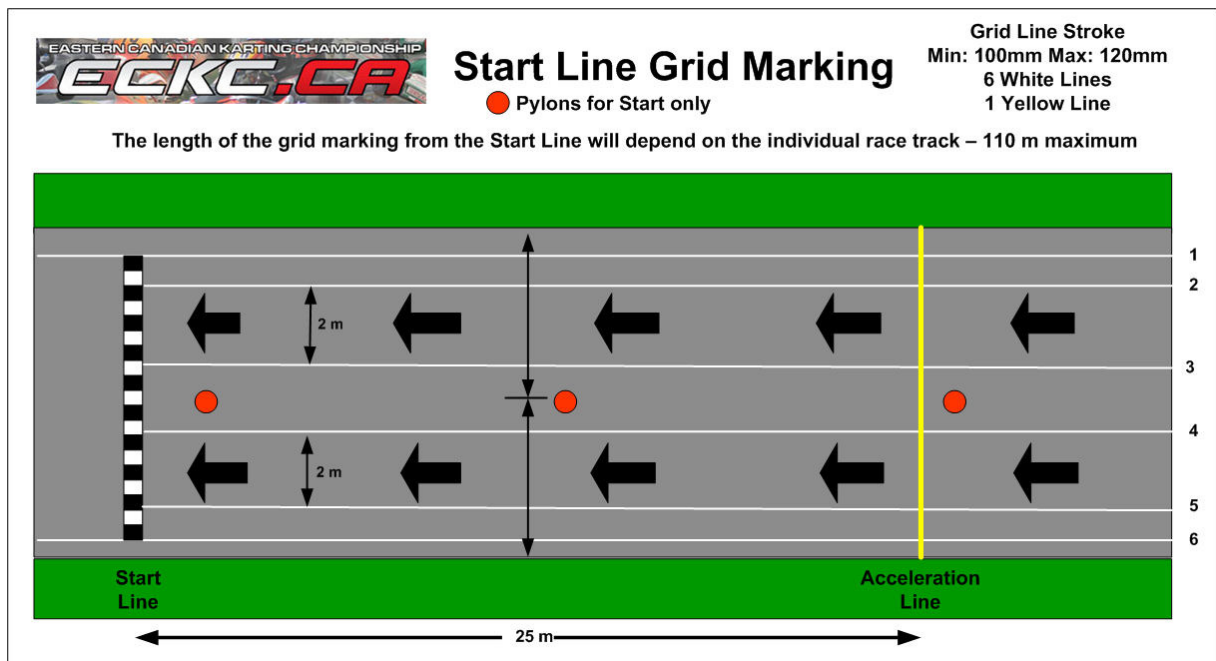

30. Use of The Blue With Red “X” Overlap Flag

This flag may be used in all Finals. It will not be used in Qualifying or Pre-finals.

The minimum penalty for disobeying a Blue With Red “X” is a \$50.00 fine.

ASN Canadian Karting Regulations Book 1, Regulation 12. Flag Signals

Shown with or without a number board to a driver about to be lapped or who has already been lapped. The driver must stop racing, maintain racing speed and return directly to the pits. Drivers who do so will be scored in the position they were in the last time they crossed the timing and scoring line.

Failure to obey this flag will result in a BLACK flag with kart number being shown, the driver will be excluded from the results and additional penalties may be issued.

31. Procedure at the End of a Qualifying Session or Race

ASN Canadian Karting Regulations Book 1, Regulation 11.20. Procedure At The End of a Qualifying Session or Race.

32. Procedure at the End of Finals

ASN Canadian Karting Regulations Book 2, Regulation 6. POST-RACE TECHNICAL INSPECTION.

The winner of the Final will do one victory lap with a Checkered Flag.

The top five (5) finishers in each Final race in each class will proceed to the Parc Fermé and remain there until released by Technical Officials.

33. Official Notice Board

The Official Notice Board is located in the Paddock.

34. Fuel

The fuel of all the junior classes, the 4 Strokes class as well as those using the Rotax motor should be use petrol pump 'Super' at the petrol stations ULTRAMAR located at:

3150 Bd St-Jean, Trois-Rivières, exit 183 of the interstate 55

35. Hotel accommodations

COMFORT INN TROIS-RIVIÈRES 6255 RUE CORBEIL, TROIS-RIVIÈRES.
(819) 371-3566

SUPER 8 MOTEL 3185 BOUL ST-JEAN, TROIS-RIVIÈRES. (819) 377-5881
1-888-561-7666

DAYS INN TROIS-RIVIÈRES 3155 BD ST-JEAN, TROIS-RIVIÈRES. (819) 377-4444

PORTES DE LA MAURICIE 4 RTE STE-ANNE O, YAMACHICHE. (819) 228-9434

URBANIA 3600 BD GENE H KRUGER, TROIS-RIVIÈRES (819) 379-3232

36. QUIET RULE IS IN FONCTION AS PER MAX CHALLENGE REGULATIONS